

# S15VB20 ~ S15VB60

PRV : 200 ~ 600 Volts

Io : 15 Amperes

### FEATURES :

- \* High current capability
- \* High surge current capability
- \* High reliability
- \* Low reverse current
- \* Low forward voltage drop
- \* Ideal for printed circuit board
- \* Pb / RoHS Free

### MECHANICAL DATA :

- \* Case : Molded plastic with heatsink integrally mounted in the bridge encapsulation
- \* Epoxy : UL94V-O rate flame retardant
- \* Terminals : plated .25" (6.35 mm). Faston
- \* Polarity : Polarity symbols marked on case
- \* Mounting position : Bolt down on heat-sink with silicone thermal compound between bridge and mounting surface for maximum heat transfer efficiency.
- \* Weight : 17.1 grams

# SILICON BRIDGE RECTIFIERS

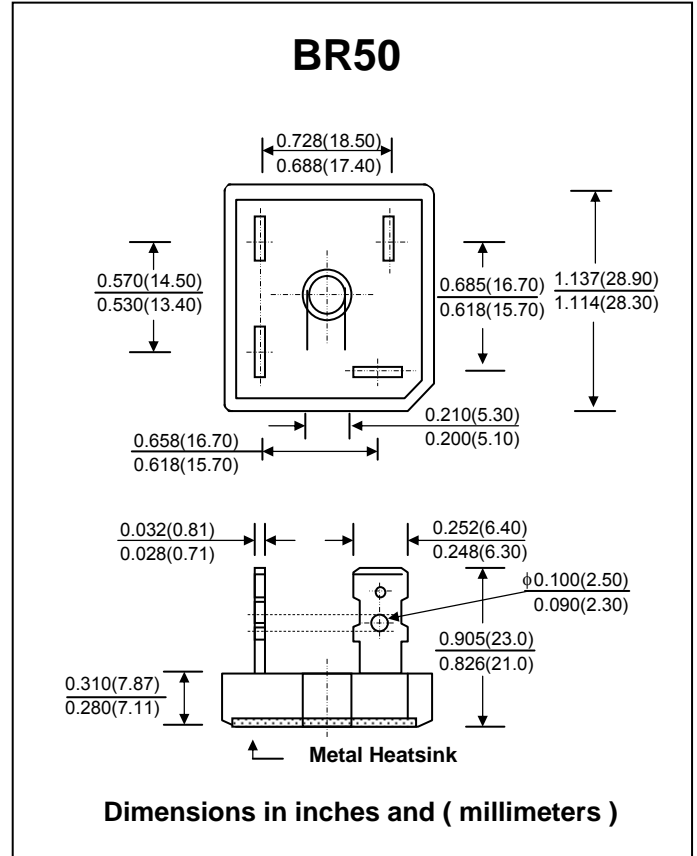

## MAXIMUM RATINGS AND ELECTRICAL CHARACTERISTICS

Rating at 25 °C ambient temperature unless otherwise specified

Single phase, half wave, 60 Hz, resistive or inductive load.

For capacitive load, derate current by 20%.

RATING	SYMBOL	S15VB20	S15VB60	UNIT
Maximum Reverse Voltage	$V_{RM}$	200	600	V
Maximum Average Forward Current $T_c = 83^\circ\text{C}$	$I_{F(AV)}$	15		A
Maximum Peak Forward Surge Current Single half sine wave Superimposed on rated load (JEDEC Method)	$I_{FSM}$	200		A
Current Squared Time at $2\text{ms} \leq t < 10 \text{ms}$ . $T_c = 25^\circ\text{C}$	$I^2t$	200		$\text{A}^2\text{S}$
Maximum Forward Voltage per Diode at $I_F = 7.5 \text{A}$	$V_F$	1.05		V
Maximum DC Reverse Current at $V_R = V_{RRM}$ (Pulse Measurement, Rating of per diode)	$I_R$	10		$\mu\text{A}$
Typical Thermal Resistance (Note 1)	$R_{\theta JC}$	2.3		$^\circ\text{C/W}$
Operating Junction Temperature Range	$T_J$	150		$^\circ\text{C}$
Storage Temperature Range	$T_{STG}$	- 40 to + 150		$^\circ\text{C}$

### Notes :

1. Thermal Resistance from junction to case with units mounted on a 5" x 4" x 3" (12.7cm.x 10.2cm.x 7.3cm.) Al.-Finned Plate



**RATING AND CHARACTERISTIC CURVES ( S15VB20 ~ S15VB60 )**

**FIG.1 - DERATING CURVE FOR OUTPUT RECTIFIED CURRENT**

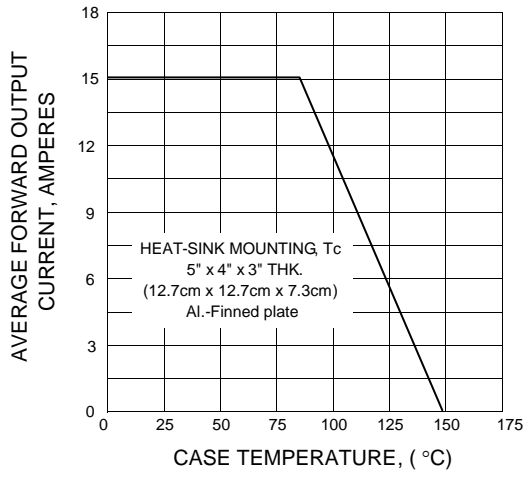

**FIG.2 - MAXIMUM NON-REPETITIVE PEAK FORWARD SURGE CURRENT**

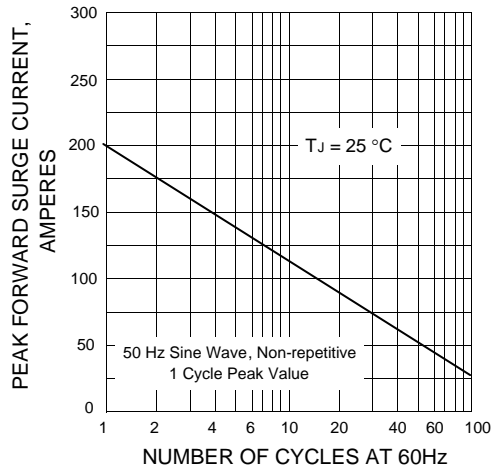

**FIG.3 - TYPICAL FORWARD CHARACTERISTICS PER DIODE**

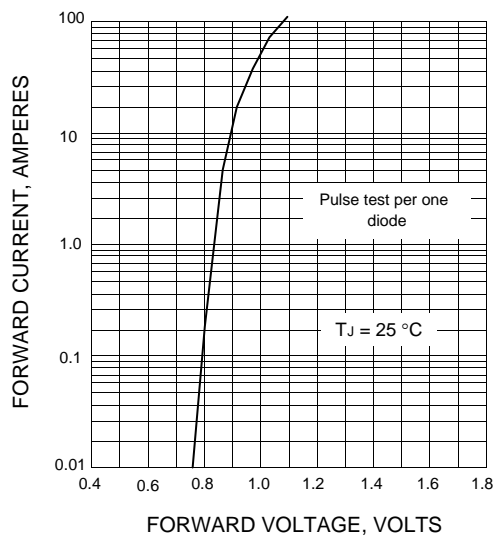

**FIG.4 - TYPICAL REVERSE CHARACTERISTICS PER DIODE**

